



DAVIS-STANDARD®

Where your ideas take shape.

Unwinding & Winding



DUAL POSITION DROP NIP UNWINDS

OVERVIEW

Davis-Standard Dual Position Unwind's rugged design is for continuous unwinding of web materials into a process in proper alignment and under automatic control of the web's tension.

Application of Drop Nip Splicing is for web speeds to 500 fpm (150 mpm).

TECHNICAL SPECIFICATIONS

Winder Width Range	36-84" in 6" increments .9-2.1 mm in 150 mm increments
Tension Ranges	5-50 lbs (20-200 kg) 10-100 lbs (45-450 kg) 20-200 lbs (90-900 kg)
Maximum Roll Diameter	40 in (1000 mm)
Core Sizes (I.D.)	3 and/or 6 inches 77 and/or 150 mm
Maximum Roll Weight	4000 lbs (1800 kg)

DUAL POSITION DROP NIP UNWINDS

FEATURES INCLUDE

- Safety chucks with optional pneumatic latching for fixed length shaftless (shown below to right)
- Electronic automatic tension control with transducer feedback
- Choice of pneumatic disc brakes for high tension or regenerative braking for low tension applications
- 6 inch (152 mm) diameter aluminum idler rolls with option of anodized aluminum
- Optional servo control automatic edge guiding and centering system with precision linear bearings
- Optional squaring incorporated into lead-out idler roll
- Optional static control system
- Optional panelview operator interface station
- Unitized design, factory prewired and piped for ease of installation and faster start-ups

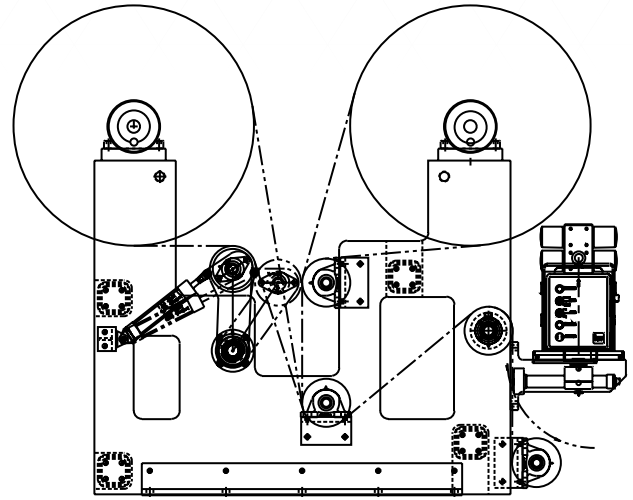

Shafted Drop Nip Unwind

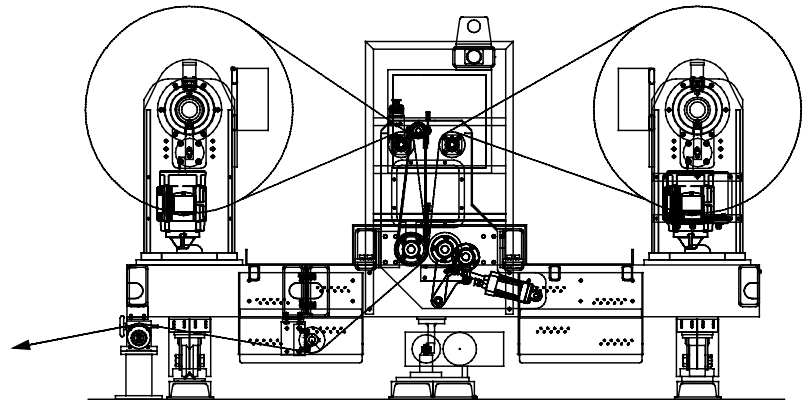

Shaftless Drop Nip Unwind with Optional Edge Guiding