



# DAVIS-STANDARD®

Where your ideas take shape.

## Winder Zip Knife

### Cut Through Your Winder Transfer Challenges

Replacing your guillotine or plunge knife with a Davis-Standard Zip Knife opens opportunities for diverse applications. The incorporation of a rotary zip knife is particularly effective for handling thick materials or those with loose fibers. Meanwhile, opting for a cut-on-core knife eliminates fold-over, ensuring a consistently smooth roll start. If you're interested in tapeless transfers, consider rolling the cut material edge into the paper core.

For higher line speeds or thicker materials, our motorized carriage option minimizes blade breaks, offering a more uniform cut. Additionally, our toolless quick-change blade holder facilitates a faster return to production. This strategic upgrade translates to improved efficiency, reducing the chances of missed transfers and minimizing downtime in your operations.

Upgrade today and experience the difference precision and innovation can make in your operations!

#### Applicable Processes:

Extrusion Coating, Laminating, Cast Film, Liquid Coating, Blown Film

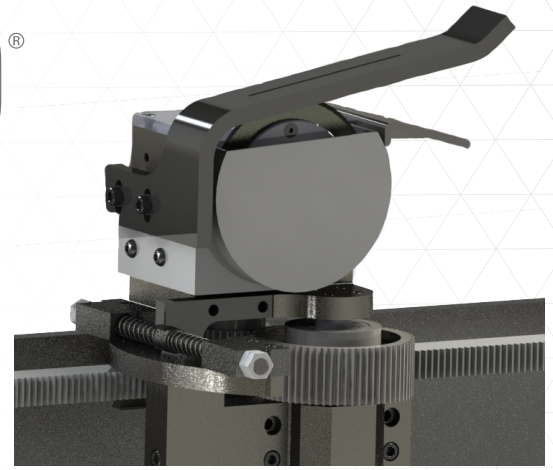
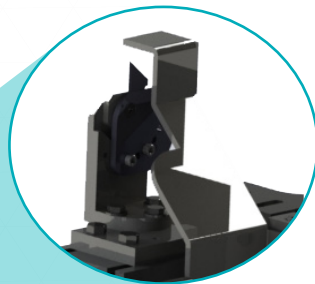
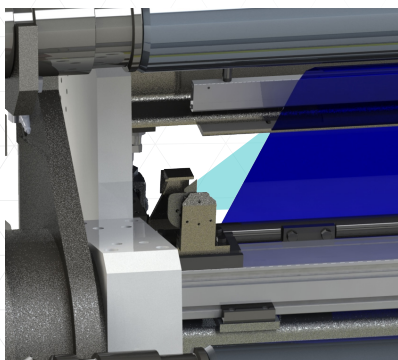

## KEY FEATURES



### Uptime

- Swift production turnaround with the toolless quick-change blade holder.
- Minimized missed cuts for improved overall productivity.
- Motorized carriage option, ideal for higher line speeds and thicker materials.



### Flexibility

- Enhanced capability for thicker, hard to cut, or loose fiber materials.
- Zero-fold-over and tapeless transfers with the cut-on-core configuration.



### Safety

- Blade guard and zero energy state during maintenance.

 **DS** GLOBAL SERVICES

[www.davis-standard.com](http://www.davis-standard.com)  
+1 860-362-2859