



DAVIS STANDARD®

Where your ideas take shape.

Tangential Shear Slitting

Cutting Edge Enhancements for Your Converting/Slitting Process

If you're encountering challenges like lost edge trim, inconsistent edges, or are looking to enhance the flexibility of your production line, consider upgrading from your current razor or score system to shear slitters. Shear slitters offer an optimal solution for cutting various materials such as paper, foils, and films across a diverse range of thicknesses.

Our adaptable slitters provide the flexibility to easily switch between shear knives and razors. Whether you prefer a tangential or wrapped configuration, we excel in optimizing the slitting geometry and roll drive to deliver superior results. We also collaborate seamlessly with all major slitter manufacturers, ensuring that we can incorporate your preferred components into a comprehensive solution.

Upgrade to our shear slitters for a marked improvement in your production process.

Applicable Processes:

Extrusion Coating, Laminating, Inline, Flexible Packaging

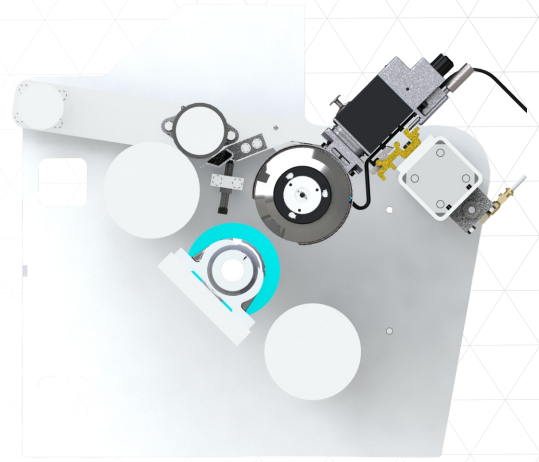
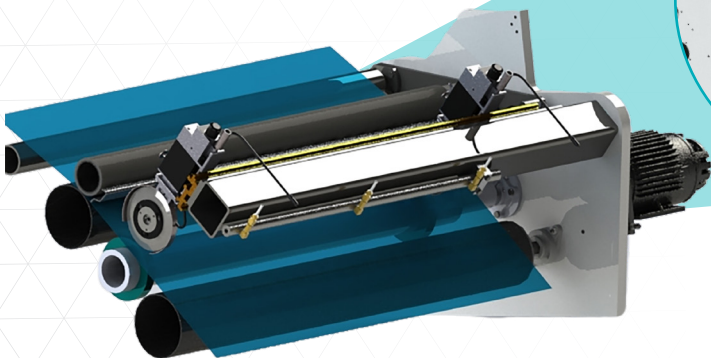

KEY FEATURES



Quality

- Improved cut width accuracy.
- Minimal dust generation.



Flexibility

- High line speed capability.
- Capable of cutting a wide range of materials.



Uptime

- Longer lasting blade life.
- Reduced interruptions due to lost trim.

 **DS** GLOBAL SERVICES

www.davis-standard.com

+1 860-362-2859