

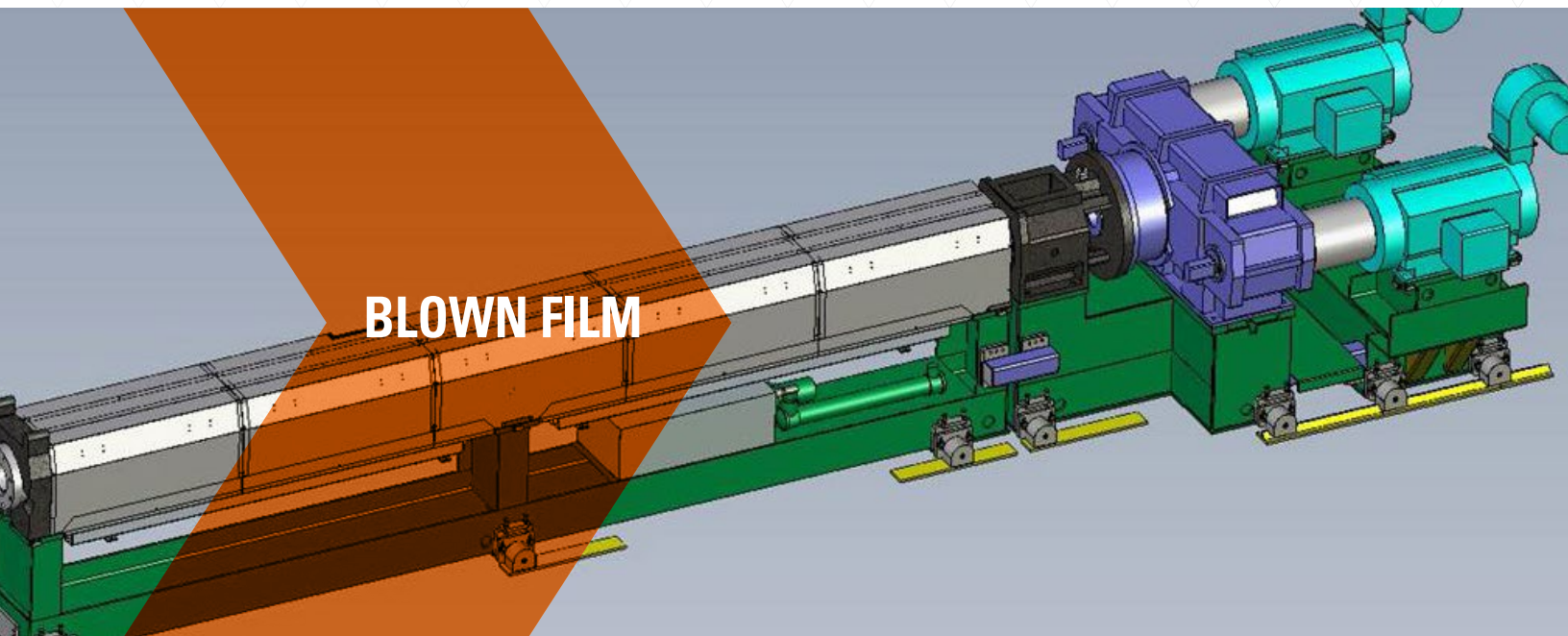

DAVIS-STANDARD®

Where your ideas take shape.

BLOWN FILM



3 LAYER GEOMEMBRANE

OVERVIEW

Davis-Standard leads the industry in experience and technology innovation on large, wide blown film systems. Based on an advanced technical knowledge base of large diameter dies, Davis-Standard provides leading edge systems for membrane and agricultural film applications.

Our Membrane Systems are available to produce 7-8 meter wide sheet with thicknesses from 0.5 to 3.0 mm. These products are used in landfill, water retention ponds, industrial ponds and aquaculture farming. Both the liner and the cap material is produced on these machines. The highest technology die system is employed to produce smooth or textured products with tight gauge control, bubble stability and highest production rates. Smooth edge options exist for making a smooth welded edge on a textured sheet. Opening units take the tube and convert it into a full width sheet in the tower. A series of winders can be employed to reduce the package size to a roll size that can be easily handled. Winders can vary from simple torque winders to more complex automated shaftless units with core feeding. These custom systems and advanced controls set the benchmark for film quality others are trying to reach. Davis Standard has recently introduced 1500mm 7-layer die to this market to create barrier membranes for specialty applications.

KEY FEATURES

- DSB screws for superior processing of resin mix giving excellent melt homogeneity
- Wave Saxton mixers for N2 dispersion on skin extruders
- MAC 30:1 smooth bore extruders for control of melt temperature
- 3 to 7 layer configurations
- Dual motor 8 inch extruders
- Water cooled core extruder with dual input gearbox with twin AC motors
- Centrex die provides excellent gauge, thermal stability and low wetted surface area
- Nip assembly with two undercut rubber rolls and extra length slat collapsers
- Special profiled tower rolls and web opening frame
- Options for torque or shaftless winding
- Option to produce agricultural film

3 LAYER GEOMEMBRANE

TECHNICAL PROPERTIES OF GEOMEMBRANE FILM

- GM13 - HDPE Geomembrane
Test methods, test properties and testing frequency of HDPE smooth and textured geomembrane
- GM17 - LLDPE Geomembrane
Test methods, test properties and testing frequency of LLDPE smooth and textured geomembrane
- Excellent Mechanical Properties
Tensile, tear, puncture and stress crack
- Endurance Properties
CB content / dispersion, Oxidative Induction Time (OIT), oven aging, UV resistance



7-Layer Agricultural Film Production

LINE CONFIGURATION

- Material Handling
Blending system including vacuum loading
- Extrusion
MAC 30:1 smooth bore skin extruders
MAC cooled 34:1 core extruder
DSB barrier screws including nitrogen injection
- Die & Air Ring
Centrex multi layer stationary IBC die with Triple Lip Air Ring
- Tower Equipment
Nip assembly with wooden slap collapsing
Web opening device
Lower nip with two nips, accumulator and hole detection
- Winding
Heavy duty winder
- Control System
Davis-Standard fully integrated controls
- Optional Services
Complete installation and commissioning
Line upgrades and components available

