



# DAVIS-STANDARD®

Where your ideas take shape.

## Soft Box

### A Clearer Product with Seamless Integration

Tired of grappling with cross-machine web shrinkage, edge curl, or compromised web clarity on your cast film line? Look no further than the Davis-Standard Softbox – the cutting-edge solution designed to enhance your film manufacturing process.

The Softbox works by applying a low-pressure blanket of chilled air over a large area. Engineered for precision and efficiency, the Davis-Standard Softbox delivers improved performance by pinning the full width of the web to the chill roll for better stabilization, increased cooling capacity, and reduced crystallization. An ideal solution for optical products and thick films.

#### Applicable Processes:

Cast Film, Extrusion

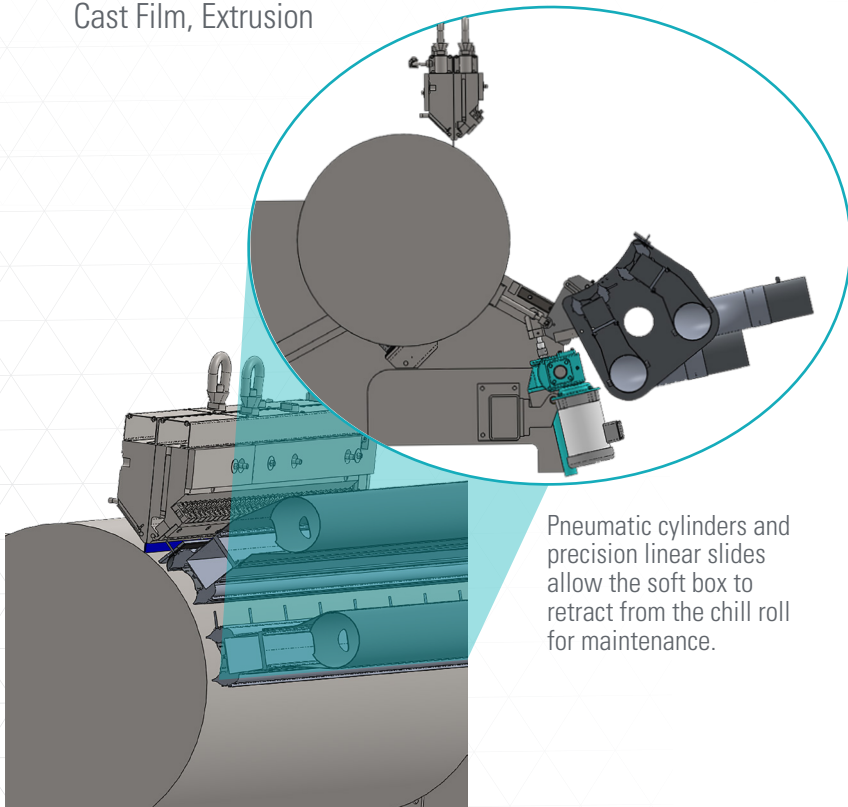

Pneumatic cylinders and precision linear slides allow the soft box to retract from the chill roll for maintenance.

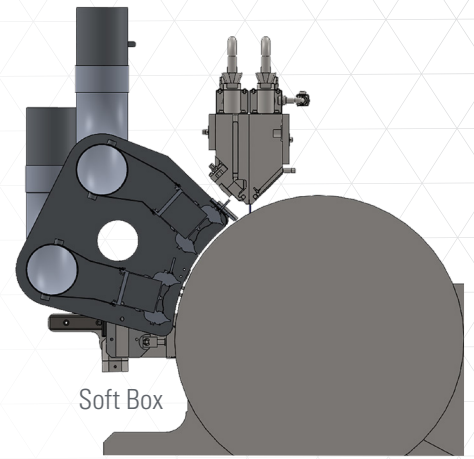

#### KEY FEATURES

##### Quality

- Minimizes Cross-Machine Direction Web Shrinkage and Edge Curl
- Improves Cooling Capacity
- Improves Web Clarity
- Beneficial on Thicker Films
- Air Filtration for Purity

##### Ease of Use

- Precise Positioning for multiple chill roll locations
- Easy Maintenance
- Operator-Friendly Controls