



# DAVIS-STANDARD®

Where your ideas take shape.

## Dual Roll Nip

### Unlocking Quality and Flexibility for Your Production Line

When it comes to your lamination or extrusion coating process, you should never have to compromise quality for flexibility. At Davis-Standard, we understand the importance of both. That's why our Dual Roll Nip system ensures uniform pressure across the entire product width while allowing you the ability to run a diverse range of products on a single production line.

Switching to a two-roll configuration enhances performance and can control the amount of precooling and polymer oxidation, reducing undesirable side effects. Achieving a high-quality bond between your layers opens up the possibilities for creating more products - giving you the flexibility you want with the quality you deserve.

### Applications

- Optimized geometry for maximum nip roll stability.
- Pneumatic or hydraulic control upgrades are also available for more refined control.
- Automatically set up pressures for a product recipe.

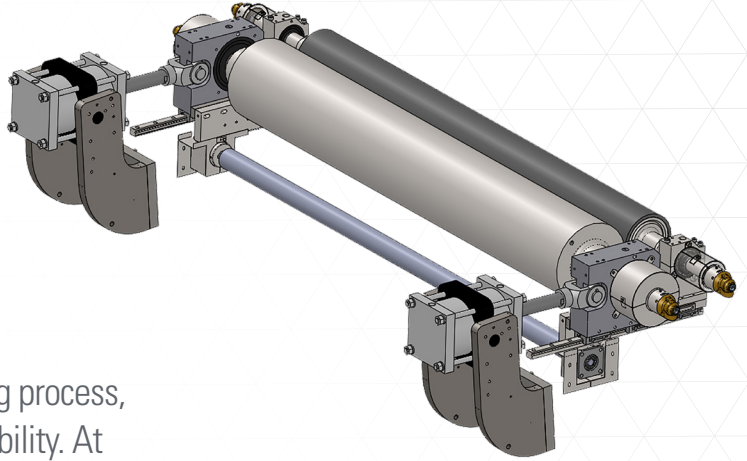

Dual Roll Nip



#### Flexibility

- A single nip roll can run a broader range of products without altering the machine.



#### Quality

- Creates a more uniform stronger bond between coated or laminated layers.

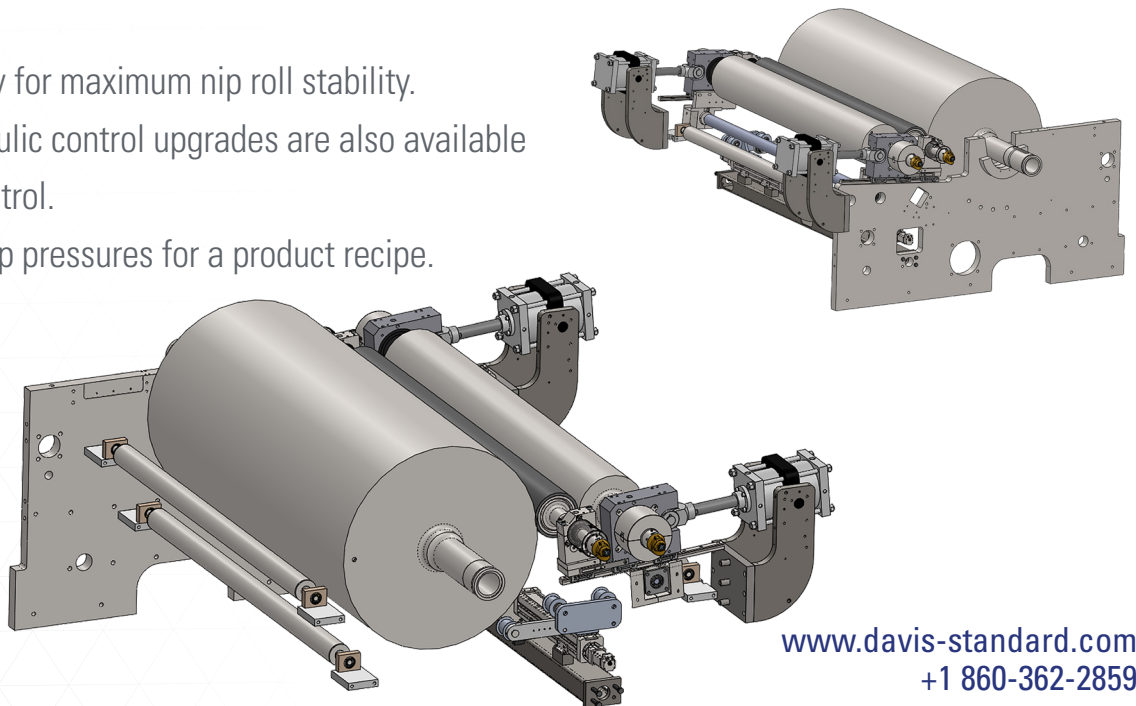

[www.davis-standard.com](http://www.davis-standard.com)  
+1 860-362-2859